

# **ILLUSTRATED PARTS LIST**

**MFG ID NO. 96011021800**

**CUSTOMER CATALOG NO. PP21H42**

**PRODUCT NO. 960 11 02-18**

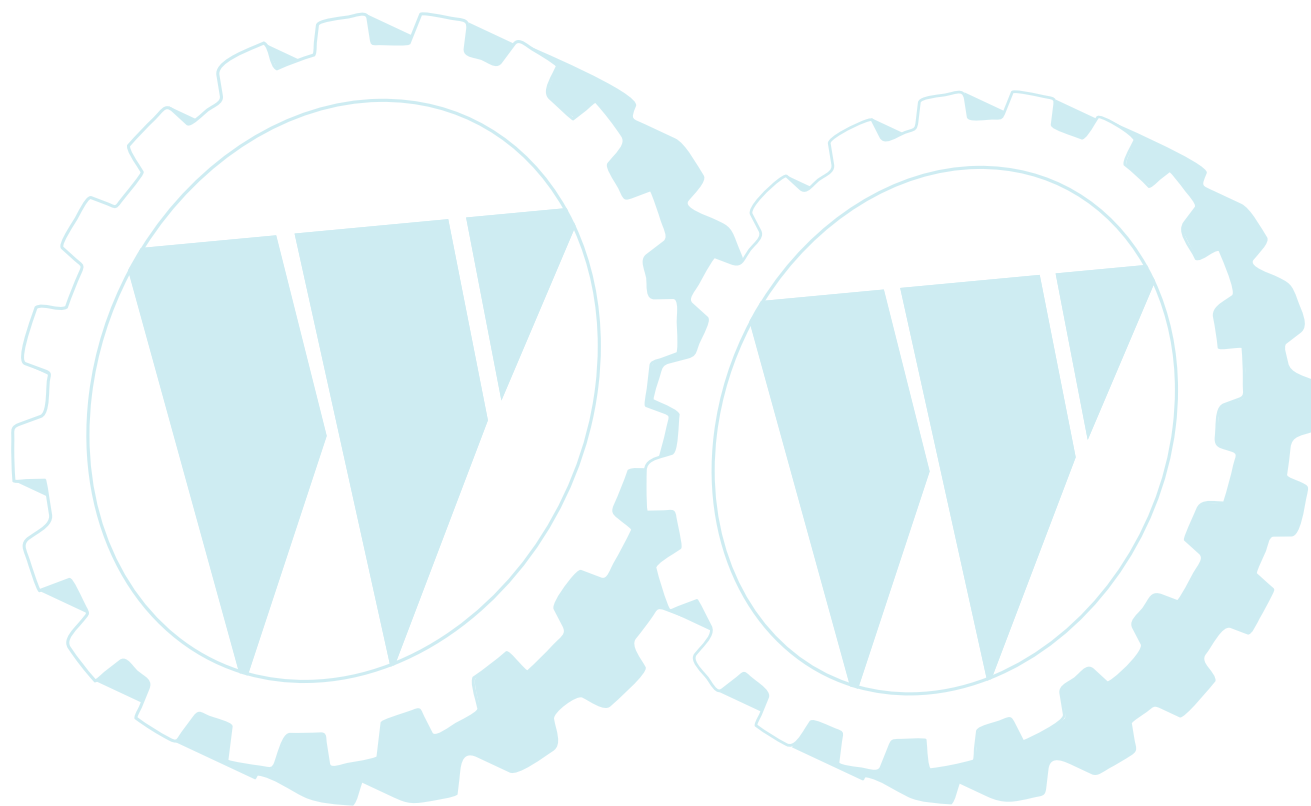

**TRACTOR -- MODEL NUMBER PP21H42 (96011021800), PRODUCT NO. 960 11 02-18  
SCHEMATIC**

03059\_197428

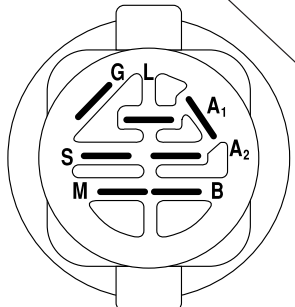
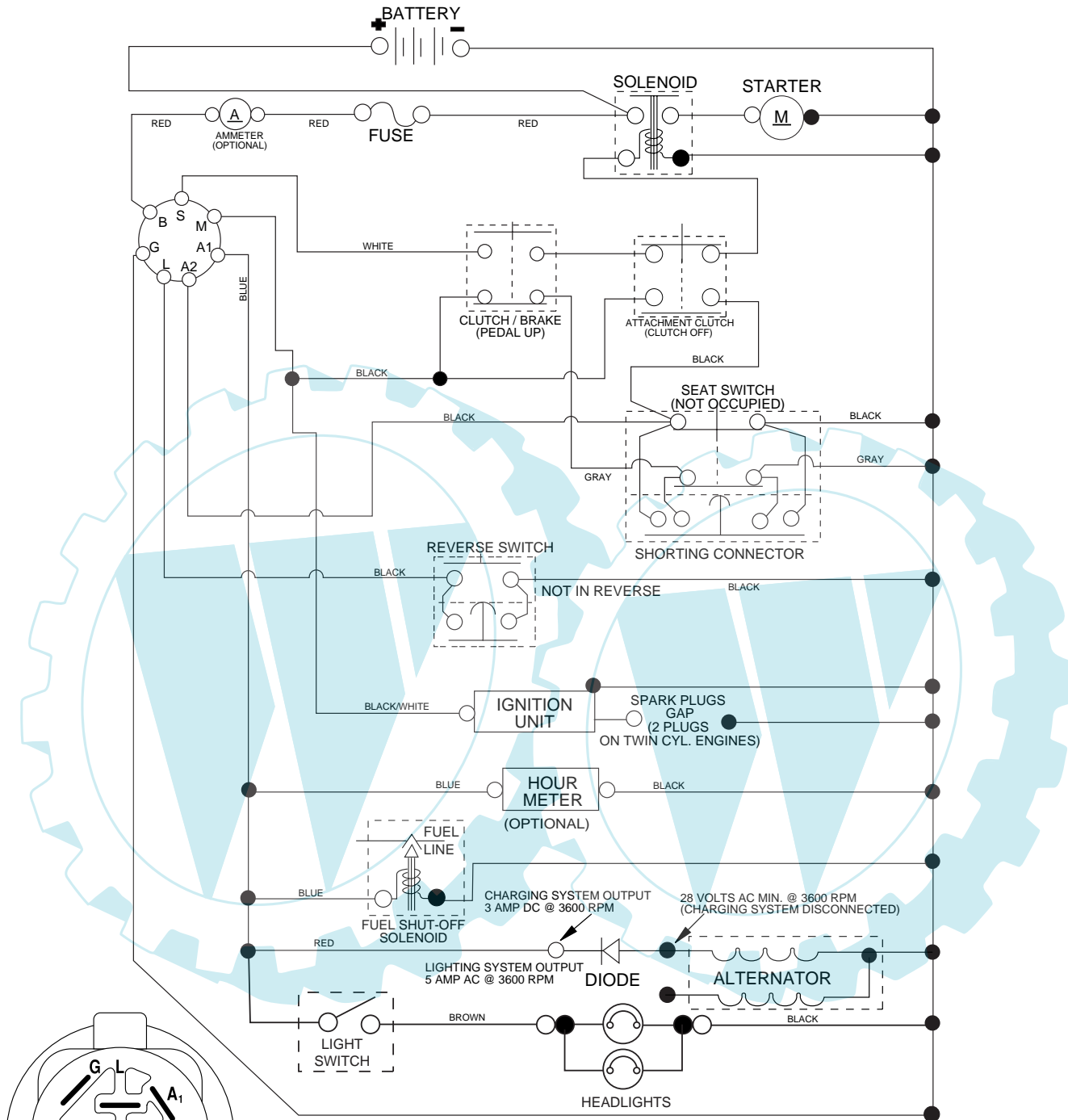

**IGNITION SWITCH**

POSITION	CIRCUIT	"MAKE"
OFF	M+G+A1	
RUN/OVERRIDE	B+A1	
RUN	B+A1	L+A2
START	B + S + A1	

03059

**NOTE**  
YOUR TRACTOR IS EQUIPPED WITH A SPECIAL ALTERNATOR SYSTEM. THE LIGHTS ARE NOT CONNECTED TO THE BATTERY, BUT HAVE THEIR OWN ELECTRICAL SOURCE. BECAUSE OF THIS, THE BRIGHTNESS OF THE LIGHTS WILL CHANGE WITH ENGINE SPEED. AT IDLE THE LIGHTS WILL DIM. AS THE ENGINE IS SPEEDED UP, THE LIGHTS WILL BECOME THEIR BRIGHTEST.



**WIRING INSULATED CLIPS**  
**NOTE:** IF WIRING INSULATED CLIPS WERE REMOVED FOR SERVICING OF UNIT, THEY SHOULD BE REPLACED TO PROPERLY SECURE YOUR WIRING.

**TRACTOR -- MODEL NUMBER PP21H42 (96011021800), PRODUCT NO. 960 11 02-18  
DECALS**

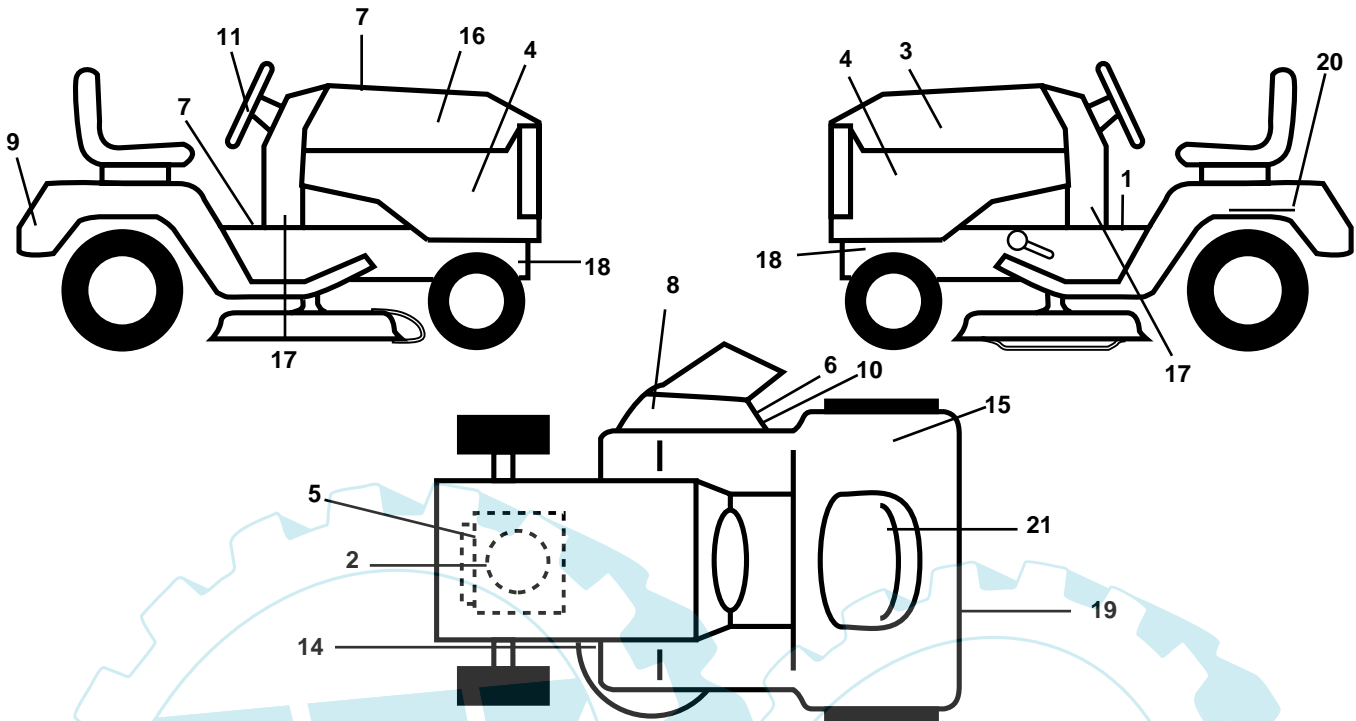

KEY NO.	PART NO.	DESCRIPTION
1	53217 83-02	Decal Operation
2	532 18 95-26	Decal Engine RP
3	532 18 61-64	Decal Hood LH
4	532 19 55-12	Decal Side Panel Logo
5	532 19 68-41	Decal Warning Eng Lym.
6	532 18 21-66	Decal Cutfinger CE
7	532 40 03-89	Decal Warning Sym CE
8	532 17 91-28	Decal Deck "B" 42"
9	532 17 27-40	Decal Fender Logo
10	532 19 63-57	Deflector Cutfinger Sym
11	532 17 27-43	Decal Ins Strg Whl
15	532 16 88-69	Decal-Tick Mark
16	532 18 61-63	Decal Hood Rh

KEY NO.	PART NO.	DESCRIPTION
17	532 40 35-68	Decal Lower Dash
18	532 15 97-36	Decal Hot Muffler
19	532 15 97-37	Decal Brake/Clutch symb
20	532 14 50-05	Decal Bat Dan/Psn
21	532 14 08-37	Decal Saddle Brake Parking
--	532 19 17-87	Pad Footrest LH
--	532 19 17-86	Pad Footrest RH
--	532 13 83-11	Decal Handle Lft Height Adjust
--	532 16 25-98	Decal Load Limit
--	532 16 69-60	Decal Bypass
--	532 40 36-87	Manual Operator's E&F
--	532 40 36-88	Manual Parts

**WHEELS AND TIRES**

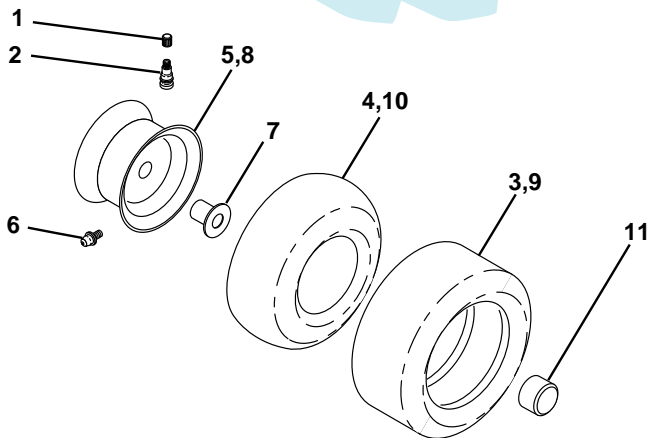

KEY NO.	PART NO.	DESCRIPTION
1	532 05 91-92	Cap Valve Tire
2	532 06 51-39	Stem Valve
3	532 10 62-22	Tire F T 15 x 6 0 - 6 Service
4	532 05 99-04	Tube Front (Service Item Only)
5	532 12 51-21	Rim Asm 6" front Service
6	532 12 49-57	Fitting Grease (Front Wheel Only)
7	532 12 49-59	Bearing Flange (Front Wheel nly)
8	532 12 51-22	Rim Asm 8" rear Service
9	532 12 20-82	Tire R T 20 x 10-8 Service
10	532 00 71-52	Tube Rear (Service Item Only)
11	532 12 49-26	Cap Axle Blk 1 50 x 1 00
--	532 14 43-34	Sealant, Tire ( 10 oz. Tube)

**NOTE:** All component dimensions given in U.S. inches  
1 inch = 25.4 mm

TRACTOR -- MODEL NUMBER PP21H42 (96011021800), PRODUCT NO. 960 11 02-18  
ELECTRICAL

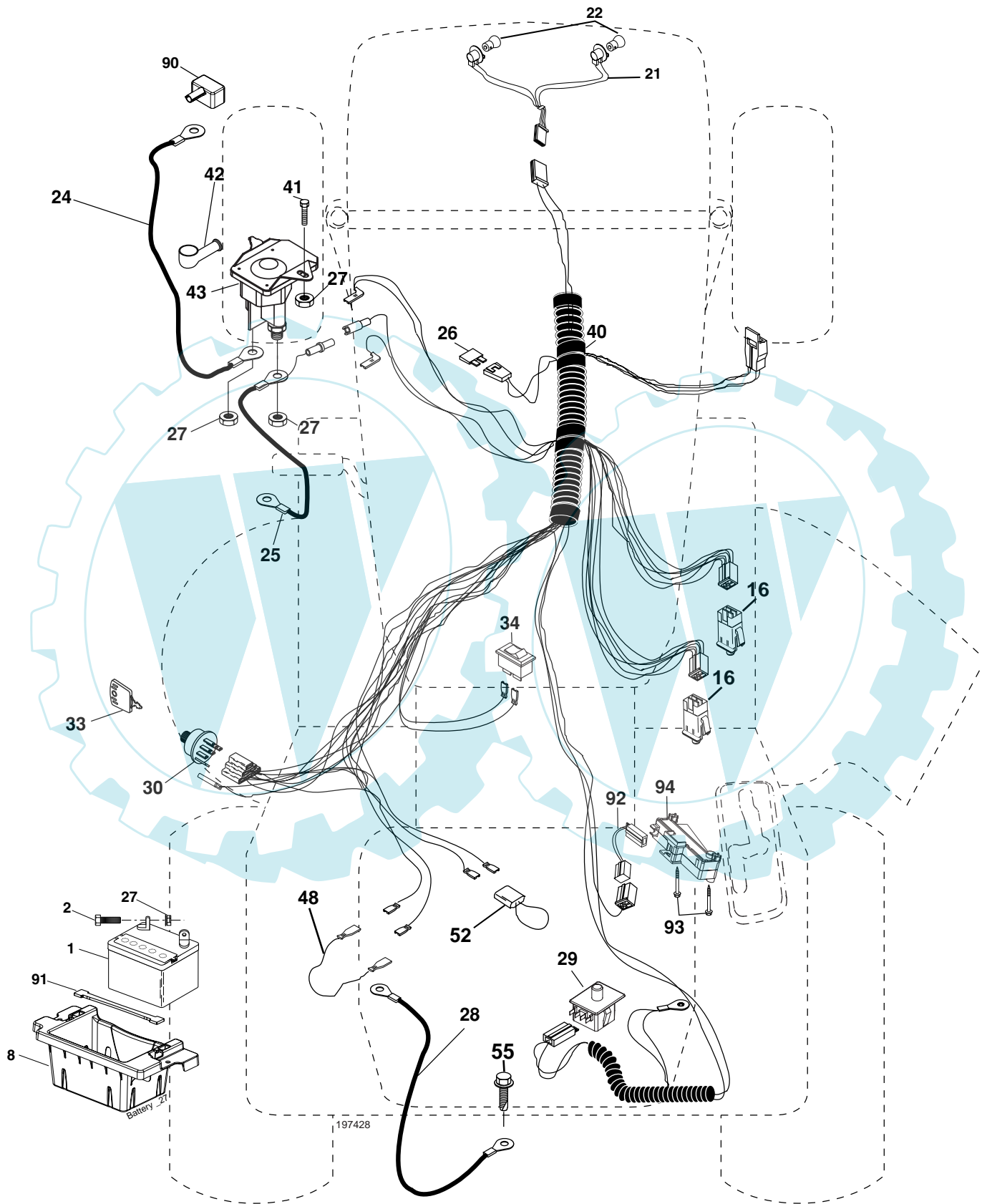

**TRACTOR - - MODEL NUMBER PP21H42 (96011021800), PRODUCT NO. 960 11 02-18  
ELECTRICAL**

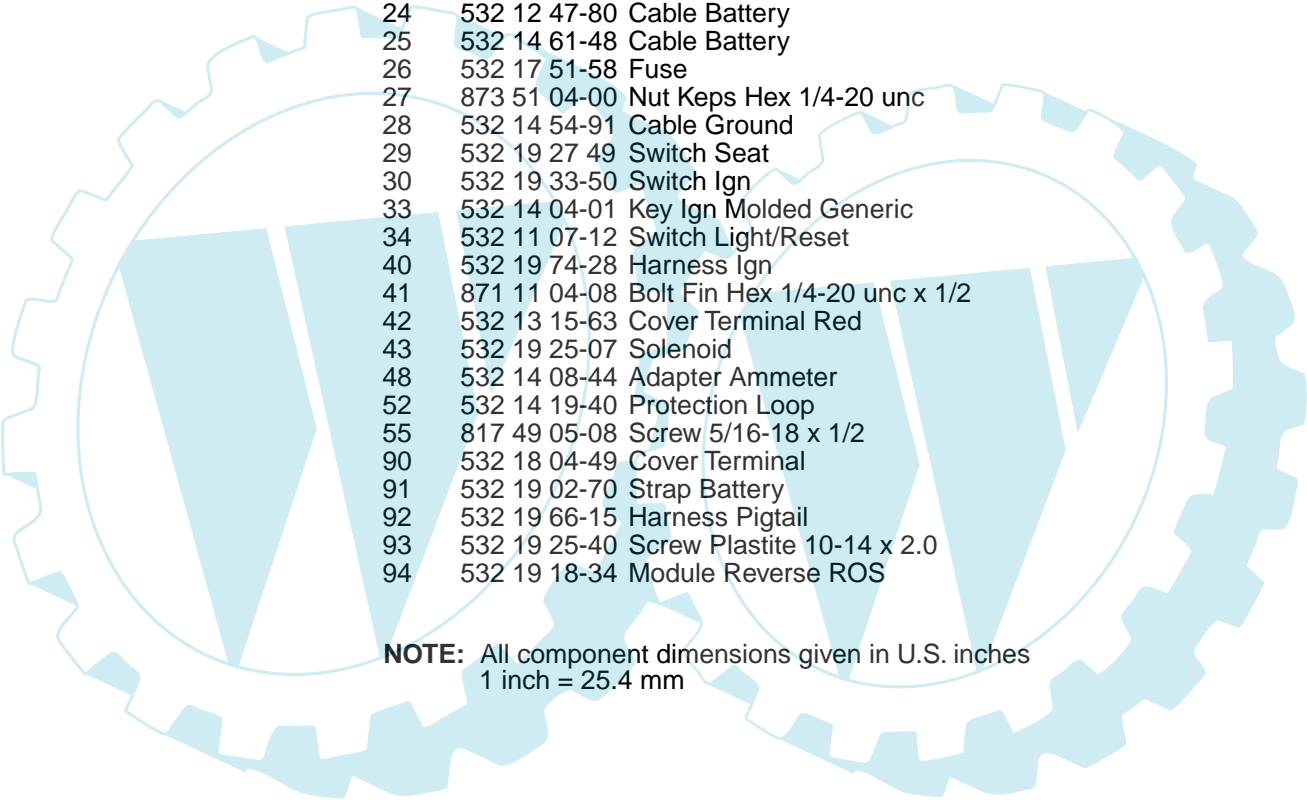

<b>KEY NO.</b>	<b>PART NO.</b>	<b>DESCRIPTION</b>
1	532 14 49-27	Battery
2	874 76 04-12	Bolt Hex Hd 1/4-20 unc x 3/4
8	532 18 64-91	Box Battery
16	532 17 61-38	Switch Interlock
21	532 18 37-59	Harness Socket Light
22	532 00 41-52	Bulb, Light # 1156
24	532 12 47-80	Cable Battery
25	532 14 61-48	Cable Battery
26	532 17 51-58	Fuse
27	873 51 04-00	Nut Keps Hex 1/4-20 unc
28	532 14 54-91	Cable Ground
29	532 19 27 49	Switch Seat
30	532 19 33-50	Switch Ign
33	532 14 04-01	Key Ign Molded Generic
34	532 11 07-12	Switch Light/Reset
40	532 19 74-28	Harness Ign
41	871 11 04-08	Bolt Fin Hex 1/4-20 unc x 1/2
42	532 13 15-63	Cover Terminal Red
43	532 19 25-07	Solenoid
48	532 14 08-44	Adapter Ammeter
52	532 14 19-40	Protection Loop
55	817 49 05-08	Screw 5/16-18 x 1/2
90	532 18 04-49	Cover Terminal
91	532 19 02-70	Strap Battery
92	532 19 66-15	Harness Pigtail
93	532 19 25-40	Screw Plastite 10-14 x 2.0
94	532 19 18-34	Module Reverse ROS

**NOTE:** All component dimensions given in U.S. inches  
1 inch = 25.4 mm

TRACTOR -- MODEL NUMBER PP21H42 (96011021800), PRODUCT NO. 960 11 02-18  
CHASSIS

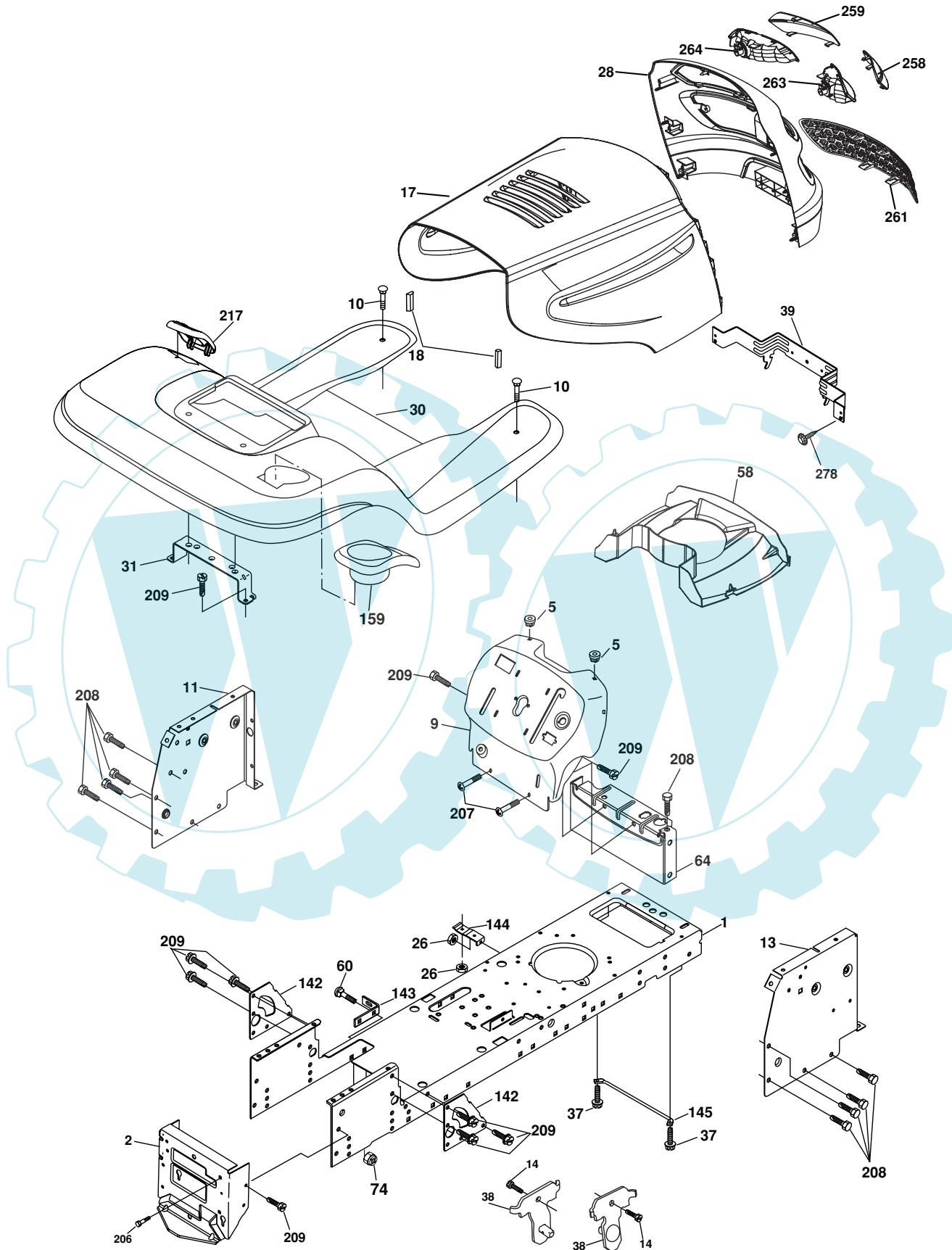

chassis\_elite sv\_pro\_20

**TRACTOR - - MODEL NUMBER PP21H42 (96011021800), PRODUCT NO. 960 11 02-18  
CHASSIS**

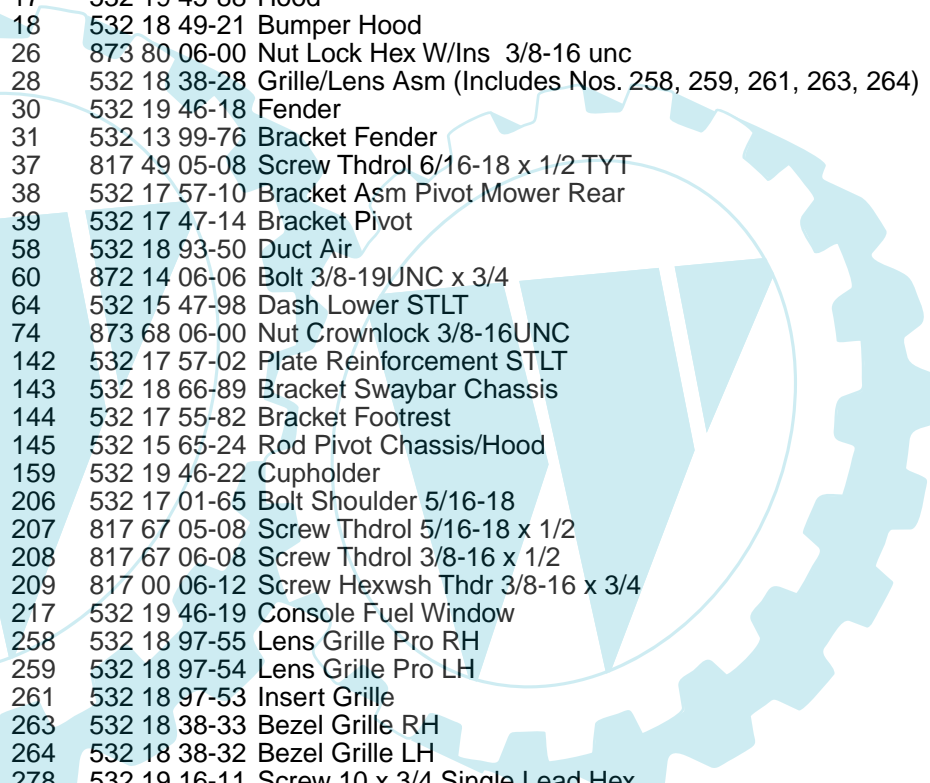

<b>KEY NO.</b>	<b>PART NO.</b>	<b>DESCRIPTION</b>
1	532 17 46-19	Chassis
2	532 17 65-54	Drawbar
5	532 15 52-72	Bumper Hood/Dash
9	532 40 51-14	Dash P/L
10	872 14 06-08	Bolt Carriage 3/8-16 x 1
11	532 17 49-96	Panel Dash Lh
13	532 17 52-55	Panel Dash Rh
14	817 49 06-08	Screw Thdrol 3/8-16 x 1/2
17	532 19 45-88	Hood
18	532 18 49-21	Bumper Hood
26	873 80 06-00	Nut Lock Hex W/Ins 3/8-16 unc
28	532 18 38-28	Grille/Lens Asm (Includes Nos. 258, 259, 261, 263, 264)
30	532 19 46-18	Fender
31	532 13 99-76	Bracket Fender
37	817 49 05-08	Screw Thdrol 6/16-18 x 1/2 TYT
38	532 17 57-10	Bracket Asm Pivot Mower Rear
39	532 17 47-14	Bracket Pivot
58	532 18 93-50	Duct Air
60	872 14 06-06	Bolt 3/8-19UNC x 3/4
64	532 15 47-98	Dash Lower STLT
74	873 68 06-00	Nut Crownlock 3/8-16UNC
142	532 17 57-02	Plate Reinforcement STLT
143	532 18 66-89	Bracket Swaybar Chassis
144	532 17 55-82	Bracket Footrest
145	532 15 65-24	Rod Pivot Chassis/Hood
159	532 19 46-22	Cupholder
206	532 17 01-65	Bolt Shoulder 5/16-18
207	817 67 05-08	Screw Thdrol 5/16-18 x 1/2
208	817 67 06-08	Screw Thdrol 3/8-16 x 1/2
209	817 00 06-12	Screw Hexwsh Thdr 3/8-16 x 3/4
217	532 19 46-19	Console Fuel Window
258	532 18 97-55	Lens Grille Pro RH
259	532 18 97-54	Lens Grille Pro LH
261	532 18 97-53	Insert Grille
263	532 18 38-33	Bezel Grille RH
264	532 18 38-32	Bezel Grille LH
278	532 19 16-11	Screw 10 x 3/4 Single Lead Hex
--	532 00 54-79	Plug BTN BIK

**NOTE:** All component dimensions given in U.S. inches  
1 inch = 25.4 mm

TRACTOR -- MODEL NUMBER PP21H42 (96011021800), PRODUCT NO. 960 11 02-18  
DRIVE

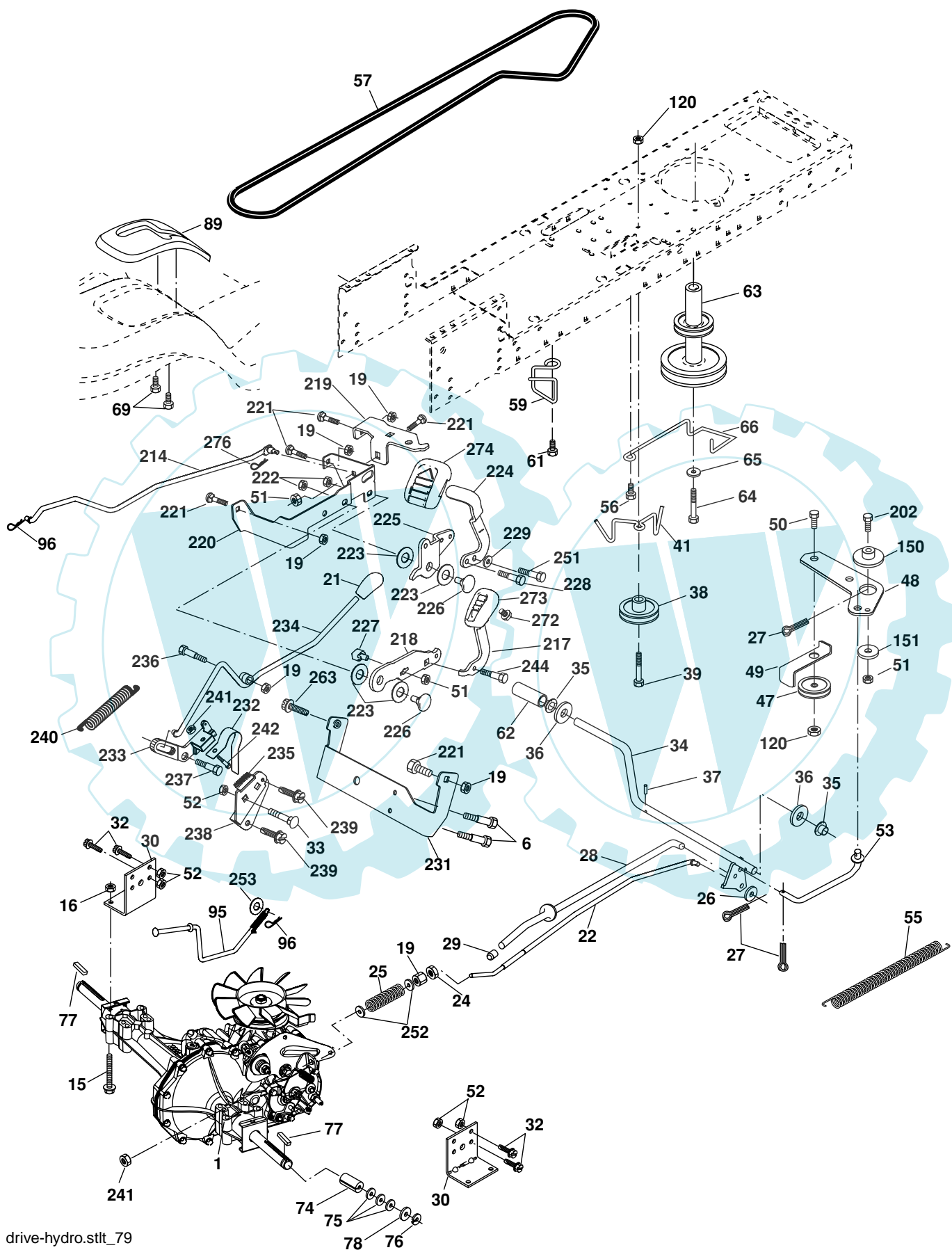

drive-hydro.sttt\_79



**TRACTOR - - MODEL NUMBER PP21H42 (96011021800), PRODUCT NO. 960 11 02-18  
DRIVE**

KEY NO.	PART NO.	DESCRIPTION	KEY NO.	PART NO.	DESCRIPTION
1	-----	Transaxle Hydro gear Model 347-0510 (See Breakdown)	89	532 19 22-59	Console, Shift
6	817 06 05-12	Screw 5/16-18 x 3/4	95	532 19 56-31	Rod Bypass
15	874 49 05-44	Bolt Hex Flghd 5/16-18 Gr. 5	96	532 12 47-88	Retainer Spring 1" Zinc/Cad
16	873 80 05-00	Nut Lock Hex W/Ins. 5/16-18 unc	116	872 14 06-08	Bolt 3/8-16 x 1
19	873 80 06-00	Nut Lock Hex W/Wsh 3/8-16 unc	120	873 90 06-00	Nut Lock Flg 3/8-16 unc
21	532 18 65-71	Knob Custom Control Cruise	150	532 17 54-56	Spacer Retainer
22	532 17 58-96	Rod, Brake	151	819 13 32-10	Washer 13/32 x 2 x 10 Ga.
24	873 35 06-00	Nut, Hex Jam 3/8-16 unc	202	872 11 06-14	Bolt RDHD 3/8-16 unc x 1-3/4 Gr. 5
25	532 19 20-36	Spring, Brake Rod	212	532 14 52-12	Nut Hex Flange Lock
26	819 13 13-16	Washer	214	532 17 47-35	Link Transaxle
27	876 02 04-12	Pin Cotter 1/8 x 3/4 CAD.	217	532 17 94-33	Pedal Reverse
28	532 17 57-65	Rod, Parking Brake	218	532 17 47-13	Arm Control Pedal Reverse
29	532 07 16-73	Cap Brake Parking	219	532 17 48-39	Bracket Frest Pdl Ctrl. Hyd
30	532 16 95-92	Bracket, Transaxle	220	532 17 47-11	Bracket Mtg. Pedal Control
32	874 76 05-12	Bolt Hex Hd 5/16-18 unc x 3/4	221	872 14 06-06	Bolt Rdhd Sqnk 3/8-16 unc x 3/4
33	872 14 05-06	Bolt Rdhd Sqnk 5/16-18 unc x 3/4	222	873 68 07-00	Nut Crownlock 7/16-14 unc
34	532 17 55-78	Shaft, Foot Pedal	223	532 17 48-40	Washer Nylon 11/16 ID x .060
35	532 12 01-83	Bearing, Nylon	224	532 17 47-36	Pedal Forward
36	819 21 16-16	Washer	225	532 17 47-12	Arm Control Pedal Forward
37	532 00 15-72	Pin, Roll	226	532 17 49-02	Bolt Pivot Spacer
38	532 17 91-14	Pulley, Composite, Flat	227	532 17 47-10	Cam Reverse Pedal LT
39	872 11 06-22	Bolt Rdhd 3/8-16 unc x 2-3/4 Gr. 5	228	532 17 90-32	Bolt Shoulder 5/16-18
41	532 17 55-56	Keeper, Belt Idler Flat	229	532 17 64-51	Washer Serrated 5/16 x .75
47	532 12 77-83	Pulley, Idler, V-Groove	231	532 40 25-50	Strap Torque
48	532 15 44-07	Bellcrank Clutch Grnd Drw Stl	232	532 17 55-70	Actuator Cruise Disengage
49	532 12 32-05	Retainer, Belt	233	532 17 48-56	Pawl Control Cruise
50	872 11 06-12	Bolt Carr Sh 3/8-16 x 1-1/2 Gr. 5	234	532 17 48-58	Lever Control Cruise
51	873 68 06-00	Nut Crownlock 3/8-16 unc	235	532 17 48-57	Sector Control Cruise
52	873 68 05-00	Nut, Crownlock 5/16-18 unc	236	532 12 89-03	Bolt Shoulder 3/8-16 unc 1/44
53	532 19 96-52	Link, Clutch	237	532 17 01-65	Bolt Shoulder 5/16-18
55	532 10 57-09	Spring, Return, Clutch	238	532 17 58-07	Arm Mtg. Cruise Sector
56	817 06 06-20	Screw 3/8-16 x 1-1/4	239	817 49 05-08	Screw Thdrol 5/16 x 1/2
57	532 14 02-94	V-Belt, Ground Drive	240	532 17 56-10	Spring Return Cruise Control
59	532 16 96-91	Keeper, Center Span	241	873 93 04-00	Nut Centerlock 1/4-20 unc
61	817 12 06-14	Screw 3/8-16 x .875	242	874 78 04-12	Bolt Fin Hex 1/4-20 x .75
62	532 00 88-83	Cover, Pedal	243	532 19 07-36	Bracket Anti-Rotation
63	532 17 54-10	Pulley, Engine	244	817 49 05-10	Screw 5/16-18 x 5/8
64	532 17 39-37	Bolt 7/16-20 x 4 x Gr.5	251	817 06 05-16	Screw 5/16-18
65	810 04 07-00	Washer	252	819 13 16-16	Washer 13/32 x 1 x 16 Ga.
66	532 15 47-78	Keeper Belt Engine	253	532 17 94-22	Washer .3125 x .615 x 16 Gr.
69	532 14 24-32	Screw Hex Wsh Hi-Lo 1/4-1/2 unc	254	817 00 06-16	Screw 3/8-16 x 1
70	532 13 46-83	Guide Mower Drive RH	263	817 00 06-12	Screw 3/8-16 x .75
74	532 13 70-57	Spacer, Axle	272	817 67 05-08	Screw, 5/16-18 x 1/2 TT
75	532 12 17-49	Washer 25/32 x 1-1/4 x 16 Ga.	273	532 17 96-10	Pad, Reverse Pedal
76	812 00 00-01	E-Ring	274	532 17 56-46	Cover Pedal Forward
77	532 12 35-83	Key, Square	276	532 17 80-62	Clip Retainer .0375
78	532 12 17-48	Washer 25/32 x 1-5/8 x 16 Ga.			

**NOTE:** All component dimensions given in U.S. inches  
1 inch = 25.4 mm

TRACTOR -- MODEL NUMBER PP21H42 (96011021800), PRODUCT NO. 960 11 02-18  
STEERING ASSEMBLY

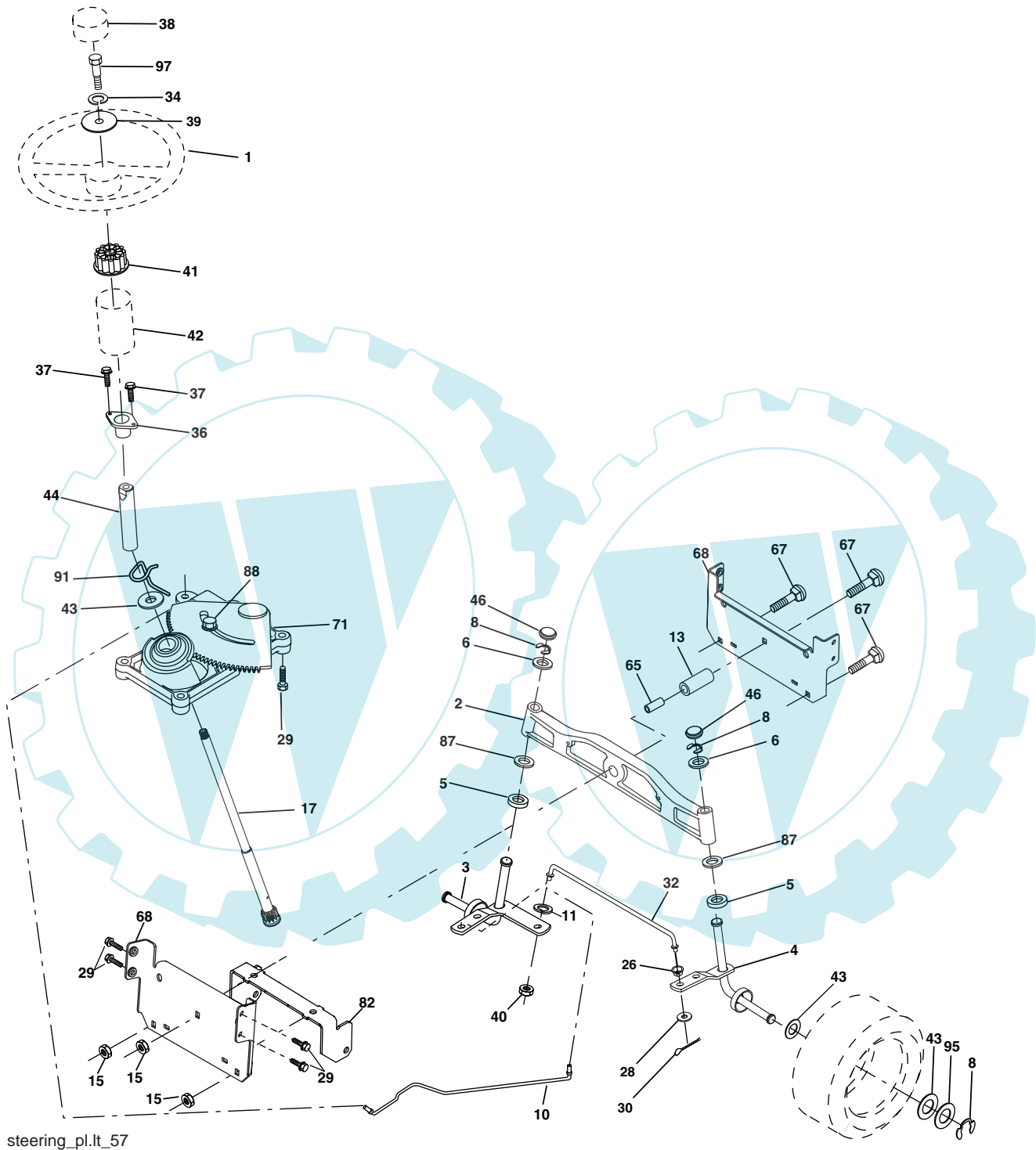

steering\_pl.lt\_57

**TRACTOR - - MODEL NUMBER PP21H42 (96011021800), PRODUCT NO. 960 11 02-18  
STEERING ASSEMBLY**

KEY NO.	PART NO.	DESCRIPTION
1	532 19 45-95	Wheel Steering
2	532 18 47-06	Axle Asm
3	532 16 98-40	Spindle Asm LH
4	532 16 98-39	Spindle Asm RH
5	532 00 62-66	Bearing Race Thrust Harden
6	532 12 17-48	Washer 25/32 x 1-5/8 x 16 Ga.
8	812 00 00-29	Ring Klip #t5304-75
10	532 17 51-21	Link Drag
11	810 04 06-00	Washer Lock Hvy Hlcl Spr 3/8
13	532 13 65-18	Spacer Brg Axle Front
15	532 14 52-12	Nut Hex Flange Lock
17	532 19 07-53	Shaft Asm Steering
26	532 12 68-47	Bushing Link Drag
28	819 13 14-16	Washer 13/32 x 7/8 x 16 Ga.
29	817 00 06-12	Screw 3/8-16 x .75
30	876 02 04-12	Pin Cotter 1/8 x 3/4
32	532 19 27-57	Rod Tie
34	810 04 05-00	Washer Lock Hvy Hlcl Spr 5/16
36	532 15 50-99	Bushing Strg
37	532 15 29-27	Screw
38	532 19 46-03	Insert Cap Strg Wh
39	819 11 38-12	Washer 11/32 ID x 2-3/8 OD 12 Ga.
40	873 54 06-00	Crownlock nut
41	532 18 67-37	Adaptor Wheel Strg
42	532 16 96-33	Boot Steering Dash
43	532 12 17-49	Washer 25/32 x 1 1/4 x 16 Ga.
44	532 19 07-52	Extension Steering Shaft
46	532 12 12-32	Cap Spindle Fr Top Blk
65	532 16 03-67	Spacer Brace Axle
67	872 11 06-18	Bolt RDHD SQNK 3/8-16 x 2 1/4
71	532 17 51-46	Steering Asm
68	532 16 98-27	Axle, Brace
82	532 19 99-78	Bracket Susp Chassis Front
87	532 17 39-66	Washer Flat .781 x 1 1/2 x .14
88	532 17 51-18	Bolt Shoulder 7/16-20 unc
91	532 17 55-53	Clip Steering
95	532 18 89-67	Washer Harden .739 x 1.637 x .060
97	874 78 05-64	Bolt 5/16-18 unc x 4" L Gr. 5

**NOTE:** All component dimensions given in U.S. inches  
1 inch = 25.4 mm

**TRACTOR -- MODEL NUMBER PP21H42 (96011021800), PRODUCT NO. 960 11 02-18  
SEAT ASSEMBLY**

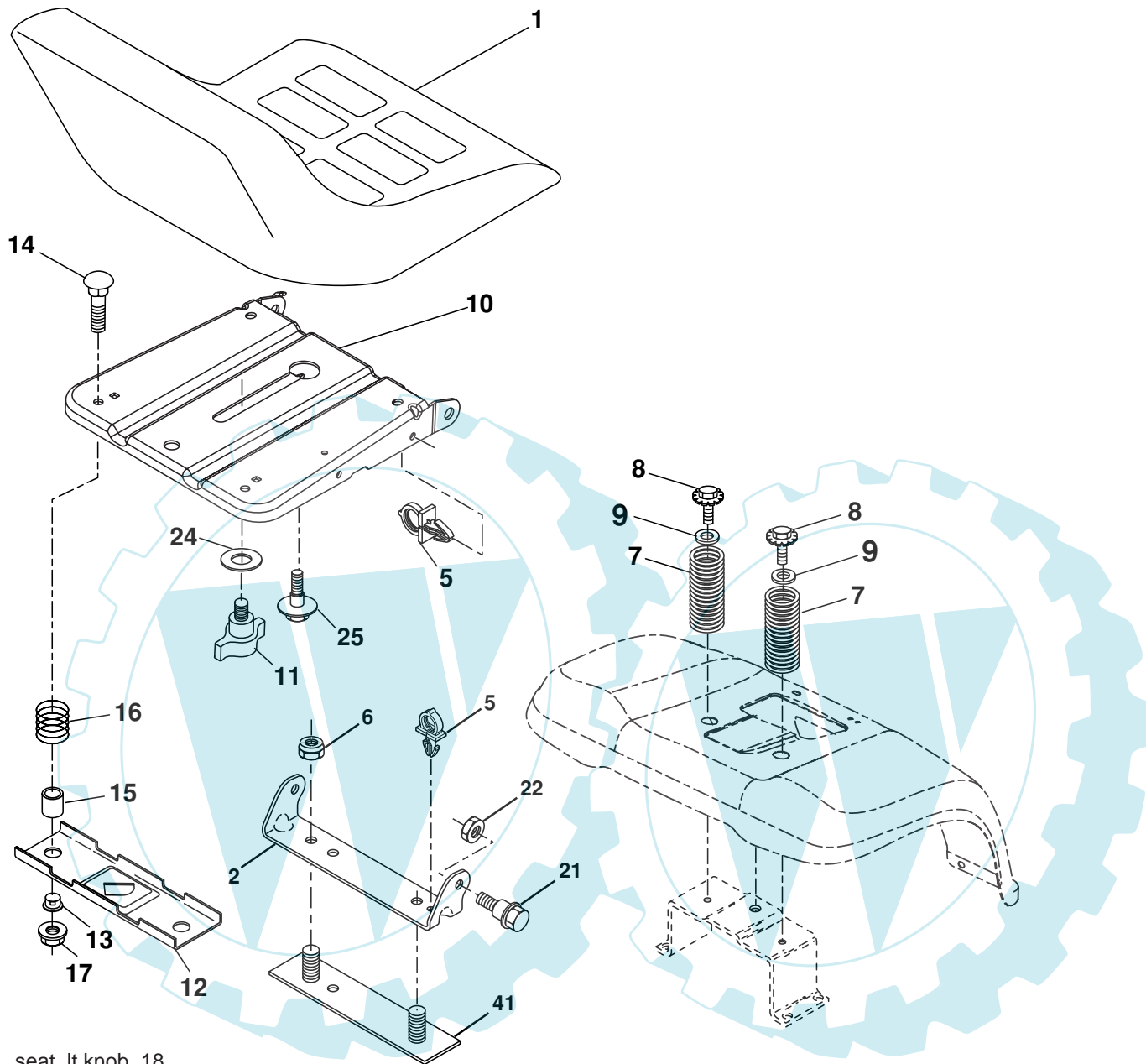

seat\_lt.knob\_18

KEY NO.	PART NO.	DESCRIPTION
1	532 1887-12	Seat
2	532 14 05-51	Bracket Pivot Seat 8 720
5	532 14 50-06	Clip Push-In
6	873 80 06-00	Nut Hex w/Ins. 3/8-16 unc
7	532 12 41-81	Spring Seat Cprsn 2 250 Blk Zi
8	817 00 06-16	Screw 3/8-16 x 1.5 Smgml
9	819 1316-14	Washer 13/32 x 1 x 14 Ga.
10	532 19 55-30	Pan Seat
11	532 16 63-69	Knob Seat
12	532 17 46-48	Bracket Mounting Switch
13	532 12 12-48	Bushing Snap Blk Nyl 50 Id
14	872 05 04-12	Bolt Rdhd Sqkn 1/4-20 x 1-1/2

KEY NO.	PART NO.	DESCRIPTION
15	532 13 43-00	Spacer Split 28x 88
16	532 12 12-50	Spring Cprsn
17	532 12 39-76	Nut Lock 1/4 Lge Flg Gr. 5 Zinc
21	532 17 18-52	Bolt Shoulder 5/16-18 unc
22	873 80 05-00	Nut Hex Lock W/Ins 5/16-18
24	819 17 19-12	Washer 17/32 x 1-3/16 x 12 Ga.
25	532 12 70-18	Bolt Shoulder 5/16-18 x 62
41	532 14 06-75	Strap Asm Fender

**NOTE:** All component dimensions given in U.S. inches  
1 inch = 25.4 mm

**TRACTOR -- MODEL NUMBER PP21H42 (96011021800), PRODUCT NO. 960 11 02-18  
ENGINE**

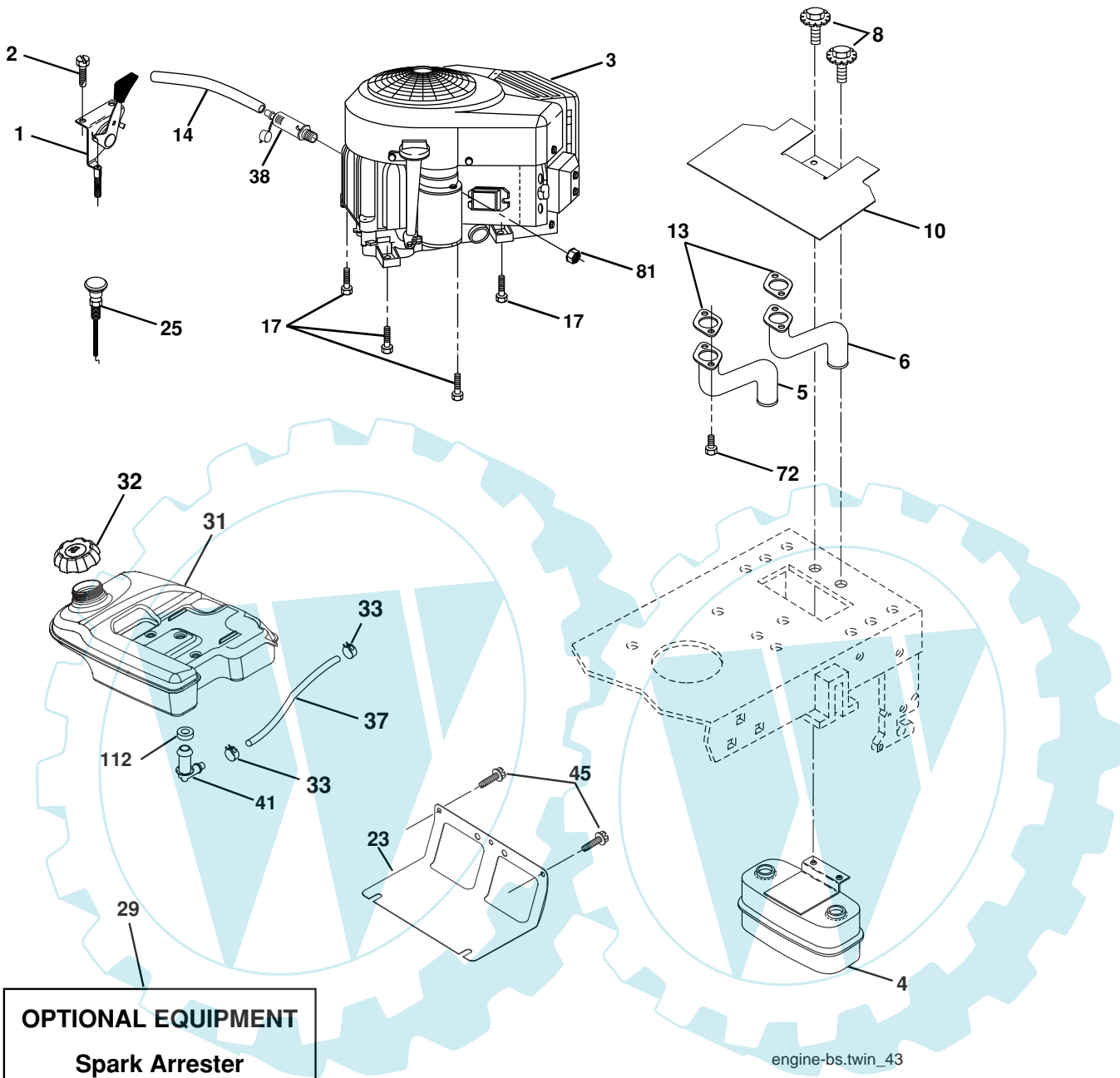

**OPTIONAL EQUIPMENT  
Spark Arrester**

engine-bs.twin\_43

KEY NO.	PART NO.	DESCRIPTION
1	532 17 05-51	Control, Throttle
2	817 72 04-08	Screw Hex Thd Cut 1/4-20 x 1/2
3	-----	Engine Briggs Model 441677 (Order Parts from Engine Mfg.)
4	532 14 97-23	Muffler
5	532 15 99-55	Exhaust Tube LH
6	532 16 05-89	Exhaust Tube RH
8	532 17 18-77	Bolt 5/16-18 x 3/4 W/Sems
10	532 16 27-97	Shield Browning
13	532 1653-91	Muffler Gasket
14	532 1484-56	Tube Oil Drain
17	817 06 06-40	Screw 3/8-16 x 1-1/2
23	532 16 98-37	Shield, Browning/Debris Guard
25	532 19 17-17	Control Choke
29	532 1371-80	Arrester, Spark
31	532 17 90-22	Tank, Fuel
32	532 18 29-02	Cap, Fuel
33	532 12 34-87	Clamp, Hose Blk

KEY NO.	PART NO.	DESCRIPTION
37	532 00 85-43	Line, Fuel
38	532 18 16-54	Plug Drain Oil Easy
41	532 13 92-77	Stem Tank Fuel
45	817 00 06-12	Screw Hex Wsh Thdrol 3/8-16 x 3/4
72	532 18 39-06	Screw Socket Head 5/16-18 x 1
81	873 51 04-00	Nut Keps Hex 1/4-20 unc
112	532 00 36-45	Bushing

**NOTE:** All component dimensions given in U.S. inches  
1 inch = 25.4 mm

For engine service and replacement parts, call the toll free number for your engine manufacturer listed below:

Briggs & Stratton	1-800-233-3723
Kohler Co.	1-800-544-2444
Tecumseh Products	1-800-558-5402
Honda Engines	1-800-426-7701
<b>13</b> Kawasaki	1-949-460-5688

TRACTOR -- MODEL NUMBER PP21H42 (96011021800), PRODUCT NO. 960 11 02-18  
MOWER DECK

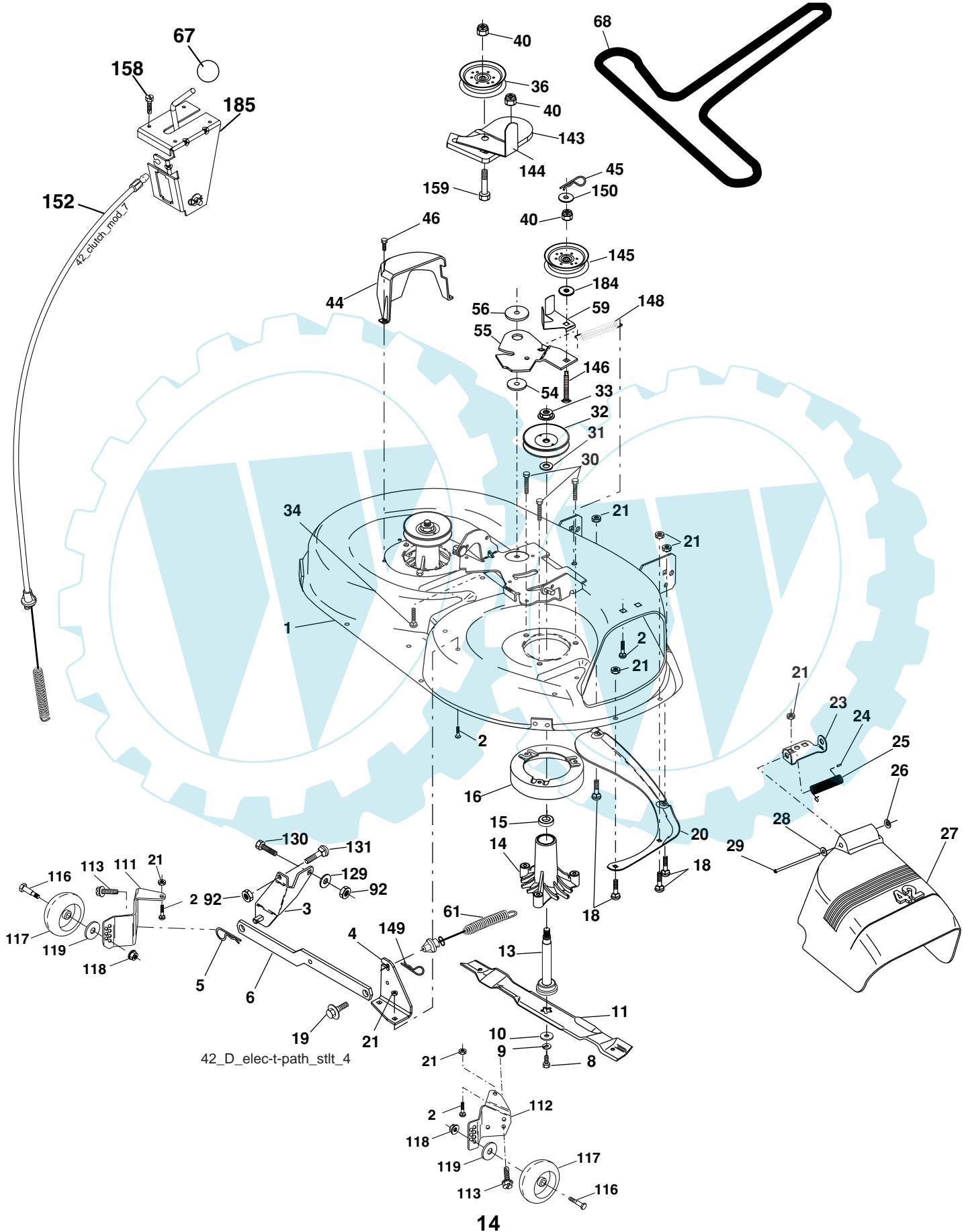

**TRACTOR -- MODEL NUMBER PP21H42 (96011021800), PRODUCT NO. 960 11 02-18  
MOWER DECK**

KEY NO.	PART NO.	DESCRIPTION	KEY NO.	PART NO.	DESCRIPTION
1	532 18 20-32	Mower Deck Assembly, 42"	55	532 15 50-46	Arm, Idler
2	872 14 05-06	Bolt	56	532 12 20-52	Spacer, Retainer
3	532 13 80-17	Bracket Asm Fr. Sway Bar 3/42	59	532 14 10-43	Guard TUV Idler
4	532 16 54-60	Bracket Asm Deck 42" Sway Bar	67	532 17 15-98	Knob
5	532 12 46-70	Retainer Spring	68	532 14 49-59	V-Belt, 42" Mower
6	532 17 80-24	Bar Sway Deck	92	873 80 06-00	Nut 3/8-16
8	532 85 08-57	Bolt 3/8-24 x 1.25 Gr. 8 patched	113	817 00 05-10	Screw 5/16-18
9	810 03 06-00	Washer, Lock	116	532 19 34-06	Bolt, Shoulder
10	532 14 02-96	Washer, Hardened	117	532 17 48-73	Wheel, Gauge
		(The following Blades are available)	118	873 93 06-00	Nut Centerlock 3/8-16
11	532 13 89-71	Blade Mower 42" Hi-Lift (for bagging and discharging)	119	819 12 14-14	Washer 3/8 x 7/8 x 14 Ga.
13	532 13 76-45	Shaft Assembly, Mandrel, Vented	129	819 13 13-12	Washer 13/32 x 13/16 x 12 Ga.
14	532 12 87-74	Housing, Mandrel, Vented	130	874 78 06-16	Bolt 3/8-16 x Gr.5
15	532 11 04-85	Bearing, Ball, Mandrel	131	872 14 06-08	Bolt 3/8-16 x 1
16	532 17 44-93	Stripper, Mandrel Deck	134	532 15 69-41	Pin Head Rivet
18	872 14 05-05	Bolt, Carriage 5/16-18 x 5/8	135	532 15 97-65	Bracket Asm Wheel Gauge LH Rear
19	532 13 28-27	Bolt, Shoulder	136	532 15 59-86	Bar Adjusting Gauge Wheel
20	532 15 97-70	Baffle, Vortex	138	532 15 97-63	Bracket Asm Wheel Gauge RH Rear
21	873 68 05-00	Nut	139	532 15 97-67	Bracket Asm Wheel Gauge RH Front
23	532 17 75-63	Bracket, Deflector Mower 42"	140	532 15 97-68	Bracket Asm Wheel Gauge LH Front
24	532 10 53-04	Cap, Sleeve 80 x 112 Blk Mower	142	532 16 58-90	Arm Spring Brake Mower
25	532 12 37-13	Spring, Torsion, Deflector 2 52	143	532 15 71-09	Bracket Arm Idler 42"
26	532 11 04-52	Nut, Push Phos & Oil	144	532 17 34-41	Keeper Belt 42" Clutch Cable
27	532 17 18-59	Shield, Deflector 42" Blk	145	532 17 34-37	Pulley Idler Flat
28	819 11 10-16	Washer 11/32 x 5/8 x 16 Ga.	146	532 17 34-43	Bolt Carriage Idler
29	532 13 14-91	Rod, Hinge 42" 6 75 W/G	147	532 13 13-35	Spring Extension
30	532 17 39-84	Screw Thdrol	148	532 16 90-22	Spring Return Idler
31	532 18 76-90	Washer, Spacer Mower Vented	149	532 16 58-98	Retainer Spring Yellow
32	532 17 34-36	Pulley, Mandrel	150	819 09 12-10	Washer 9/32 x 3/4 x 10 Ga.
33	532 40 02-34	Nut, Toplock	152	532 16 96-76	Clutch Cable 42"
34	872 11 06-12	Bolt Carr SH 3/8-16 x 1-1/2 Gr.5	158	817 72 04-08	Screw Hex Thd Cut 1/4-20 x 1/2
36	532 17 34-38	Pulley, Idler, Flat	159	872 14 06-14	Bolt Rdhd Sqn 3/8-16 unc x 1-3/4
40	873 90 06-00	Nut Lock 3/8-16	184	819 13 14-10	Washer 13/32 x 7/8 x 10 Ga.
44	532 14 00-88	Guard, Mandrel, LH	183	532 19 42-08	Pin Cotter 5/16 Bowtie Lock
45	532 00 44-97	Retainer	185	532 18 82-34	Head Asm Cable Clutch
46	532 13 77-29	Screw, Thdrol 1/4-20 x 5/8 T	--	532 13 07-94	Mandrel Assembly (Includes Hous- ing Shaft and Shaft Hardware Only - Pulley Not Included)
48	532 13 39-44	Washer, Hardened	--	532 18 45-63	Replacement Mower, Complete (Std. deck-Order seperately gauge wheel componants Key Nos. 116- 119)
52	532 13 98-88	Bolt, Shoulder 5/16-18 unc			
53	532 18 49-07	Arm Assembly, Pad, Brake			
54	532 17 85-15	Washer, Hardened			

**NOTE:** All component dimensions given in U.S. inches  
1 inch = 25.4 mm

**TRACTOR -- MODEL NUMBER PP21H42 (96011021800), PRODUCT NO. 960 11 02-18  
MOWER LIFT**

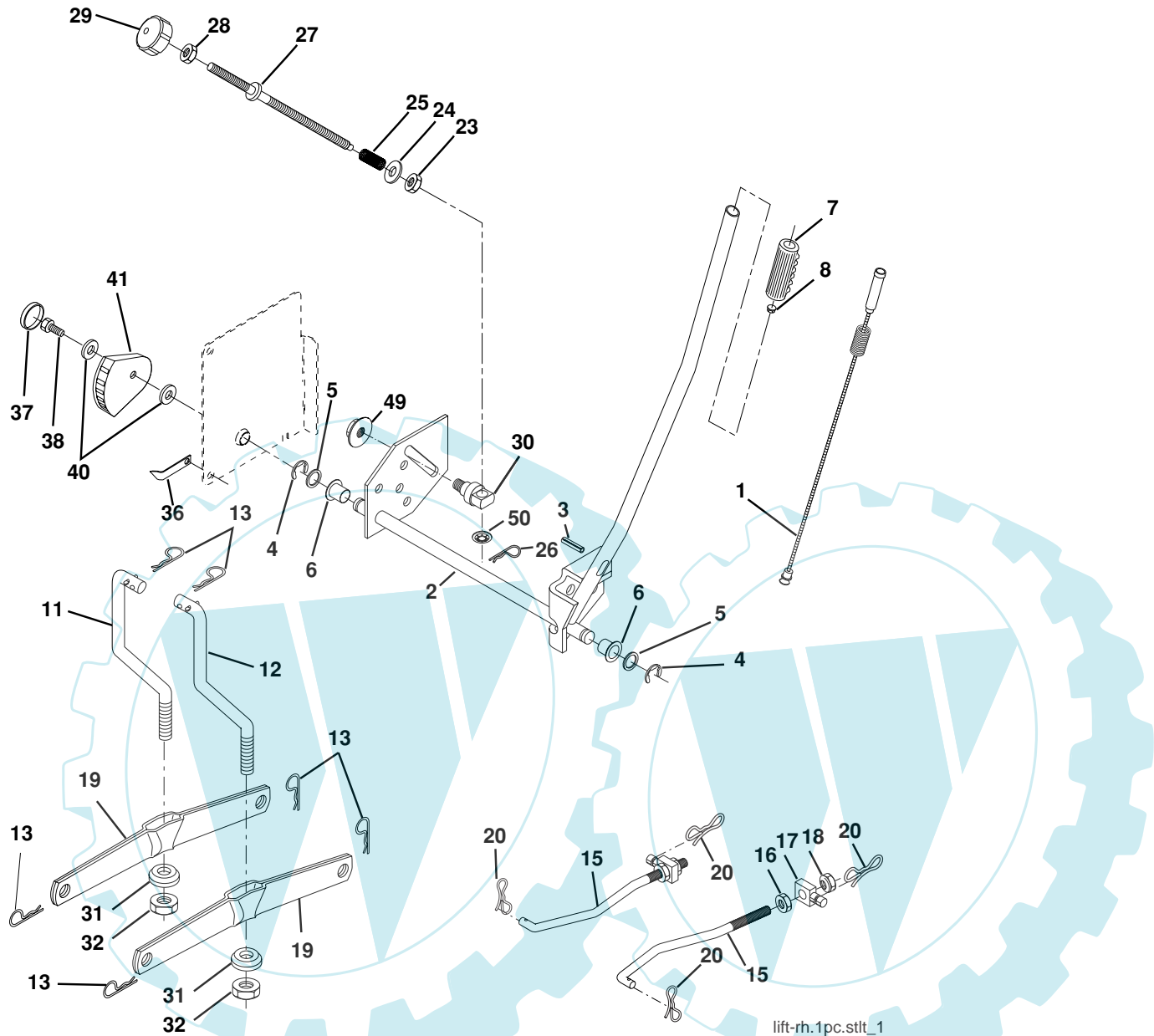

lift-rh.1pc.stlt\_1

KEY NO.	PART NO.	DESCRIPTION
1	532 19 84-17	Wire Asm Inner/Sprg W/plunger
2	532 19 80-70	Shaft Asm Lift RH w/Inf
3	532 18 88-22	Pin Groove 5/16 Dia x 1.875
4	812 00 00-02	E Ring #5133-62
5	819 21 16-21	Washer 21/32 x 1 x 21 Ga.
6	532 12 01-83	Bearing Nylon Blk 629 Id
7	532 12 56 31	Grip Handle
8	532 17 07-70	Button Plunger
11	532 13 98-65	Link Lift LH Fixed Length
12	532 13 98-66	Link Lift RH Fixed Length
13	532 12 46-70	Retainer Spring
15	532 17 32-88	Link Front
16	873 35 08-00	Nut Jam Hex 1/2-13 unc
17	532 17 56-89	Trunnion
18	873 80 08-00	Nut Lock W/Wsh 1/2-13 unc
19	532 13 98-68	Arm Suspension Rear
20	532 19 42-09	Pin Cotter 7/16 Bow Tie Lock
23	532 11 08-07	Nut Special
24	819 13 10-16	Washer 13/32 x 5/8 x 16Ga.
25	532 12 48-74	Spring

KEY NO.	PART NO.	DESCRIPTION
26	532 16 94-84	Retainer Clip
27	532 12 69-71	Rod Adj Lift
28	873 35 06-00	Nut Hex Jam 3/8-16UNC
29	532 13 80-57	Knob
30	532 15 02-33	Trunnion
31	532 16 98-65	Bearing Pvt Lift
32	873 54 06-00	Nut Crownlock 3/8 - 24
36	532 15 50-97	Pointer Height Ind.
37	532 12 39-35	Plug Hole
38	817 06 05-16	Screw 5/16-18 x 1
40	819 11 24-10	Washer 11/32 x 1-1/2 10Ga.
41	532 15 50-98	Scale Height Ind.
49	532 14 52-12	Nut Hex Flange Lock
50	532 11 04-52	Nut Push

**NOTE:** All component dimensions given in U.S. inches  
1 inch = 25.4 mm